



ABYSS GLASS

INTERACTIVE MIRRORS



OUTSHINE YOUR COMPETITION

# NEW TECHNOLOGY **FOR YOUR BUSINESS DEVELOPMENT**

---

Abyss Glass produces modern information mediums in the form of interactive mirrors.

Including them in the project for your customer will allow you to create an innovative proposal for the development of the building.



HOTELS



APARTMENTS



OFFICE  
BUILDINGS



SHOPPING  
MALLS



STATIONS



AIRPORTS

## BENEFITS FOR YOU

---

- Interactive mirror creates new profit opportunities for your customers, so that they are more likely to choose your offer.
- Interactive mirrors create modern image of your company and make it more popular in the industry.
- You stay ahead of your competition and gain argument in price negotiations with the customer.



# INNOVATIVE AND LUXURIOUS SPACE

Buildings, in which the mirrors are installed, look very modern and prestigious.

Our products look best in elevators, bathrooms, corridors or lobbies.





## PROJECT

---

We adjust mirror's projects to individual customers needs.

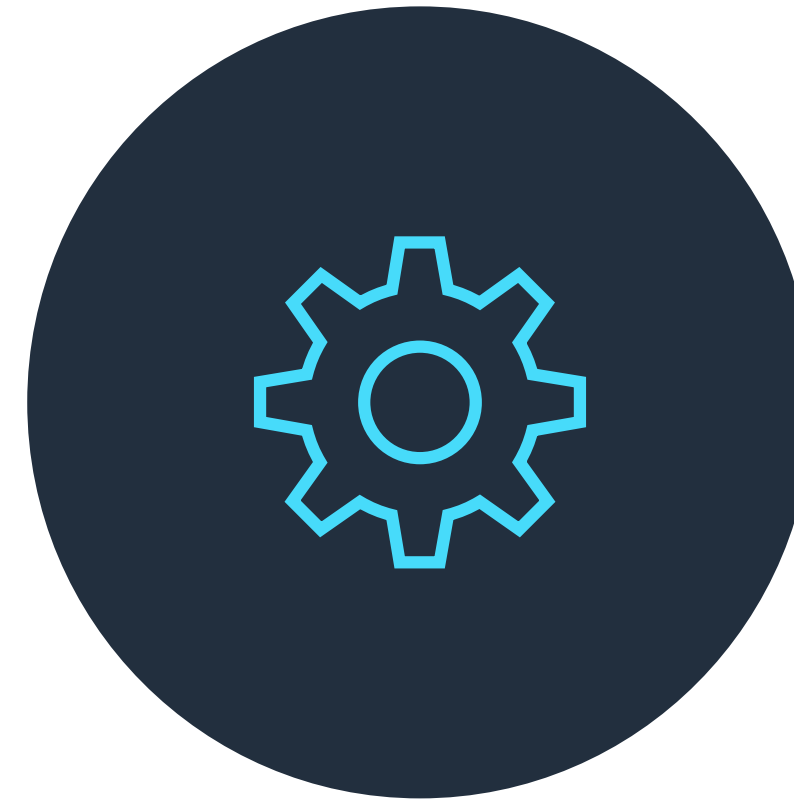

## PRODUCTION

---

We take care of efficient functioning, and high resolution of display.



## INSTALLATION

---

We are responsible for installing the mirror and presenting its functions.



## OUR **TECHNOLOGY**

---

### **TOUCHSCREEN**

The mirror's surface is the advertising space, which displays your store's offer.

### **PERSONALISED FUNCTIONS**

The ability to display individually selected content for specific groups of people.

### **HIGH QUALITY SENSORS**

They detect people in front of the mirror, and recognize their age, gender or mood.

### **INDIVIDUALLY ADJUSTED FRAME**

Custom-made, discreetly fits into your business space.

# ADVANCED DATA ANALYSIS

With our cloud based software you have remote access to all data generated by your customers.

The data include:

- total amount of users
- gender and age
- satisfaction rating
- emotions range
- time of usage
- preferences and interests

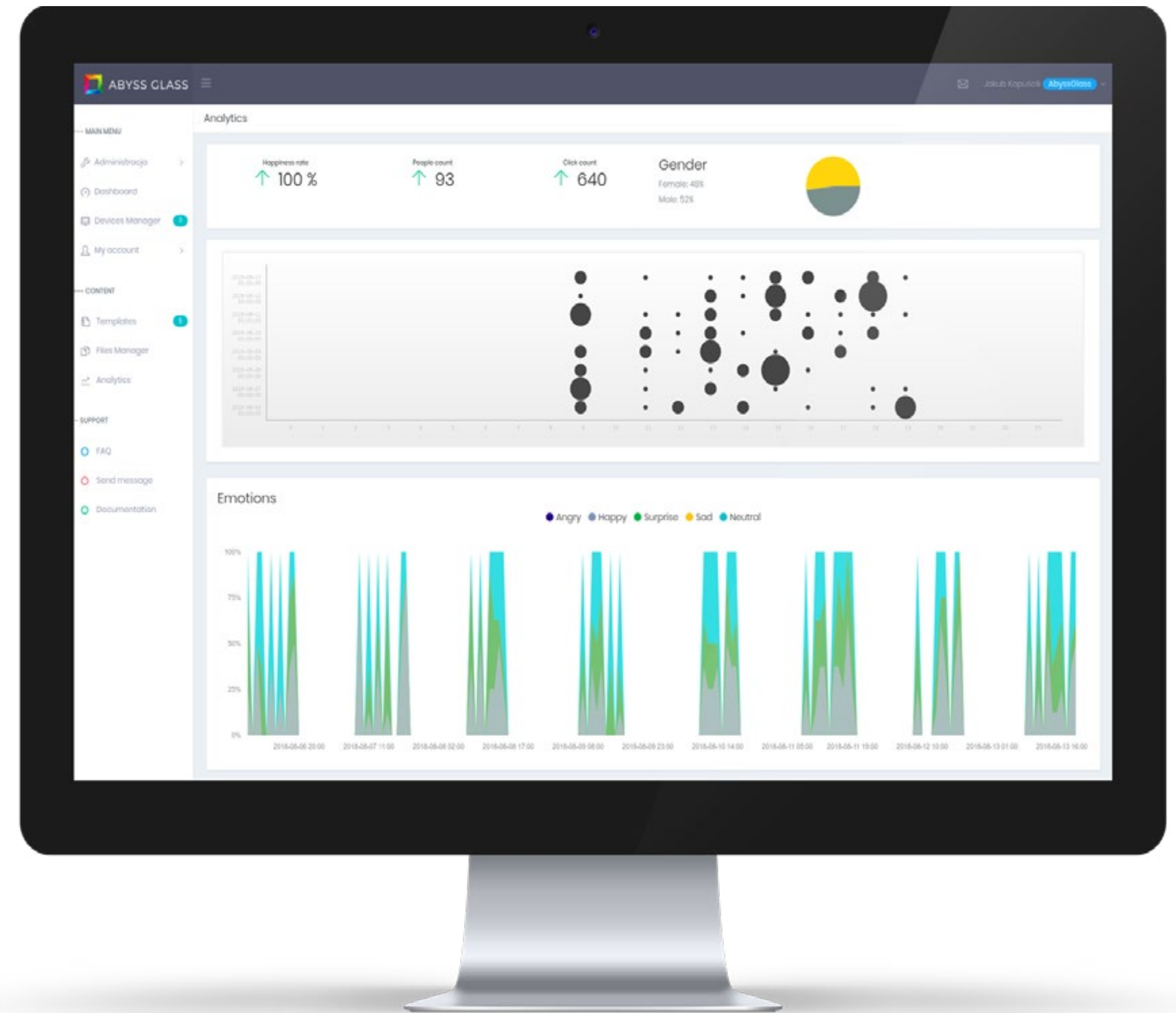

## APPLICATION EXAMPLE

# GAS STATION

### GOAL:

Generating additional sales.

### PLACE OF INSTALLATION:

Toilets at the gas station in Prague, Czech Republic.

### APPLICATION:

After somebody approached the washbasin, personalized marketing content was displayed. The product offer adapted to the time of day.

## SALES DATA

GAINED AFTER TWO MONTHS OF USING MIRRORS

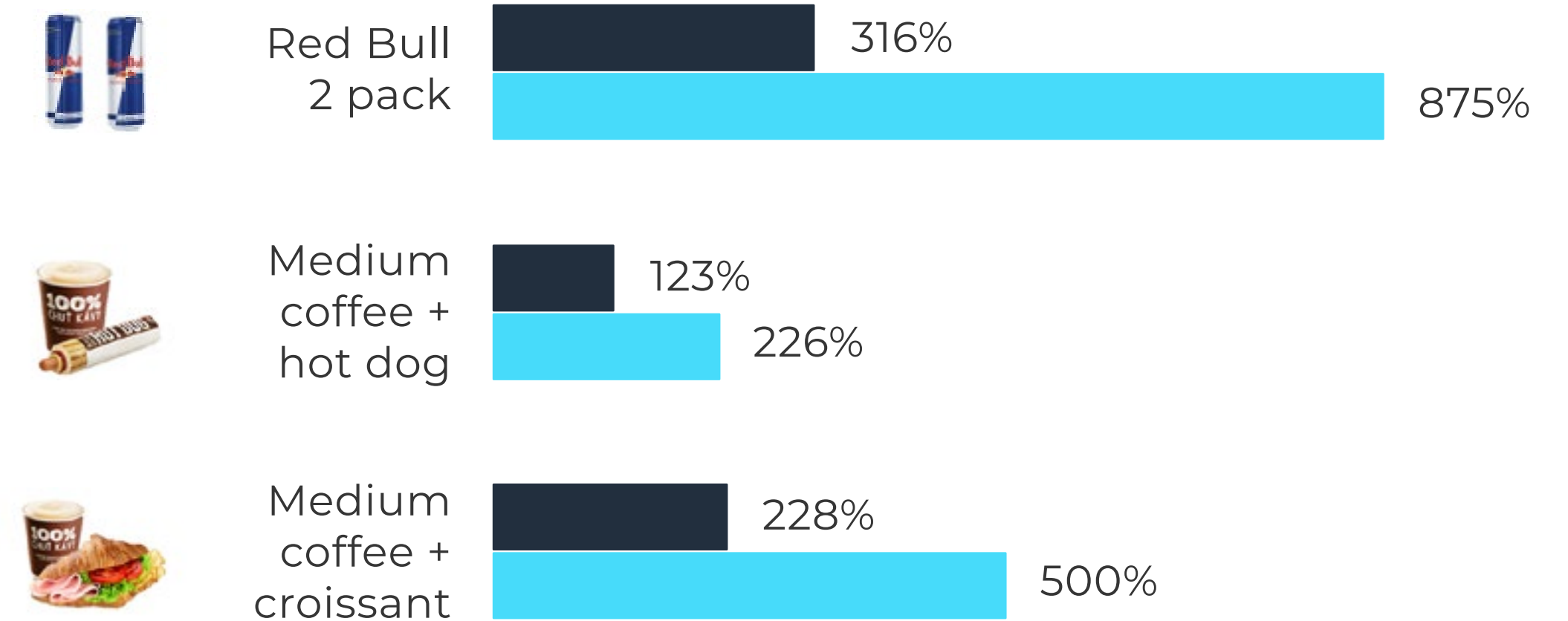

IN COMPARISON WITH MAY AND JUNE 2016

■ MAY ■ JUNE



# TECHNICAL DETAILS FOR THE 60" MIRROR

- **Power supply**  
Standard power supply  
230V  
Single electric socket
- **Power consumption**  
Below 200W
- **Working conditions**  
24/7
- **Weight**  
~ 55kg
- **Preferred connection type**  
LAN or WiFi
- **Resolution**  
Full Hd
- **Sensors' type**  
Infrared
- **IP protection degree**  
42
- **IEC protection classes**  
Class I

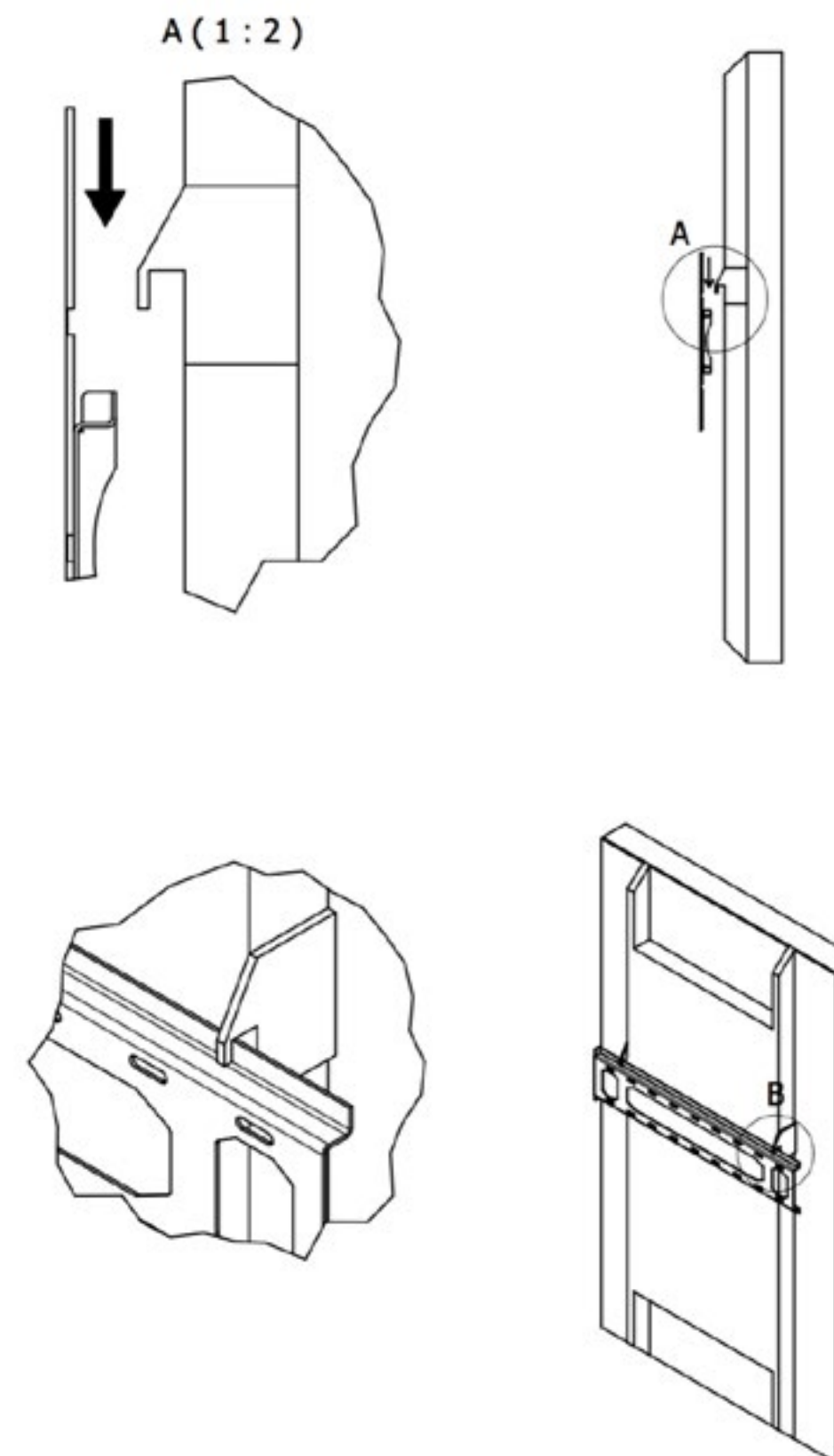
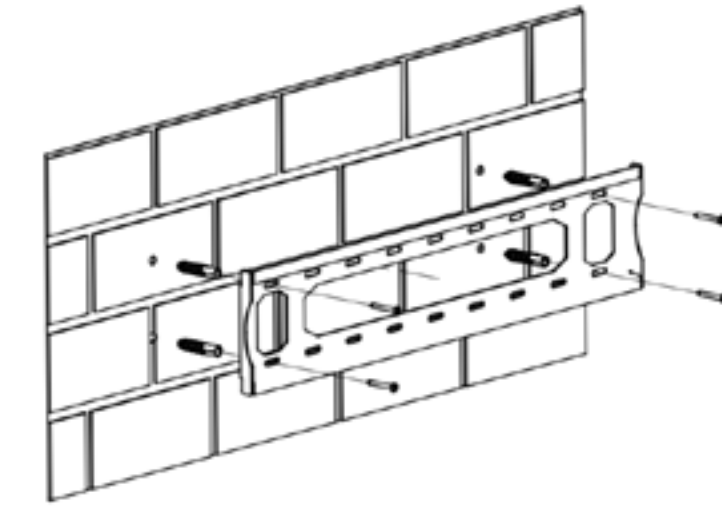

## 5 REASONS WHY **CUSTOMERS WILL CHOOSE YOUR OFFER**

- Interactive information medium allows them to present building offer in a creative way.
- Additional advertising space will increase their revenues.
- Mirrors will give the building a modern, luxurious decor.
- Prestigious and original display of offers will raise the rank of the brand.
- The mirror can be a source of passive income for your clients.



# EVEN 90% OF ALL SHOPPING DECISIONS ARE BASED ON EMOTIONS

It also applies to your clients: they choose projects arousing interest and offering real benefits.

Secure your advantage at the start - propose the installation of interactive mirrors in the building.



## STAY AHEAD **OF YOUR COMPETITION**

---

Do not hesitate to contact us,  
if you have any questions.

MARCIN  
**MOTYKA**

---

+48 534 480 829  
m.motyka@abyssglass.pl  
www.abyssglass.pl

